



Get **PAL** in Your Laboratory  
to **Ensure Reliability**  
**Enhance Productivity**  
**Enable Flexibility**



## ChroZen PAL LSI System

ChroZen PAL LSI(Liquid Sample Injection) System is a robot that can reach any three dimensional position within its working space and is ideally suited to pick and place objects like vials. It can inject from several sample containers into different inlets or transport vials from a tray to a temperature controlled modules like the agitator for heating samples or the peltier stack for cooling them down to 4°C. Ensuring superior repeatability, ChroZen PAL LSI system provides liquid sample injection with large sample capacity(648 of 2ml vials).



## ChroZen PAL RSI/RTC System

ChroZen PAL RSI(Robotic Sample Injection)/RTC(Robotic Tool Change) systems can be adapted or extended to provide the combined injection techniques such as static headspace injection, liquid injection, SPME(Solid Phase Micro Extraction) and ITEX(In-Tube Extraction) dynamic headspace on one instrument.

ChroZen PAL RSI/RTC systems have numerous options that allow to increase sample capacity and add change injection techniques or modules for sample preparation. The basis for precise and accurate handling of gaseous and liquid samples are formed by PAL's mechanical precision and robustness.

The PAL RSI's open and modular architecture makes the PAL the most versatile system and the tools can be exchanged readily within minutes.

ChroZen PAL RTC system provides same reliability, flexibility and productivity as the RSI system but it additionally offers the robotic tool change that switches between different tools automatically. This means you can run the unattended analysis including complex sample preparations and injections.

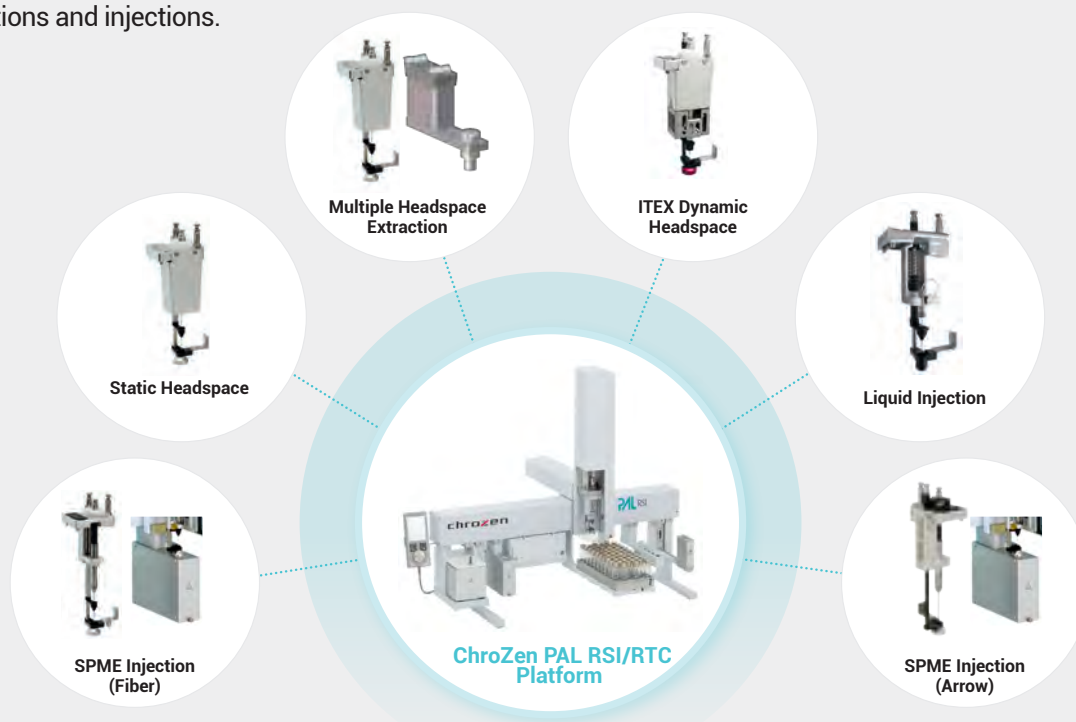

## Instrument Lineup

Model	Injection Technique Compatibility						Syringes	Features			
	Liquid	Static HS	MHE	ITEX DHS	SPME	Sample Prep.		Tool Change	Fast Injection	Vial Bottom Sensing	Vial Detection
ChroZen PAL LSI	✓	×	×	×	×	×	Liq: 1.2 µL – 100 µL <sup>#</sup>	No Tool Change	✓	✓ <sup>1)</sup>	✓
ChroZen PAL RSI	✓*	✓*	✓*	✓*	✓*	✓	Liq: 1.2 µL – 1 mL HS: 1 mL – 5 mL <sup>#</sup>	*Manual Tool Change	✓	✓ <sup>1)</sup>	✓
ChroZen PAL RTC	✓	✓	✓	✓	✓	✓	Liq: 1.2 µL – 1 mL HS: 1 mL – 5 mL	Robotic Tool Change	✓	✓ <sup>1)</sup>	✓

<sup>#</sup>Standard Syringe for Liquid Injection : 10 µL  
Headspace Injection : 2.5 mL

\* Manual Tool Change  
<sup>1)</sup> In the Specific Condition

## Compatible with Most GC

ChroZen PAL systems can be powerfully controlled by not only YL-Clarity but most well known CDS(Chromatography Data System) and there is the individually specialized mounting kit for most popular GC provided as well. This enhances PAL's compatibility to give chances to GC users to meet the ingenious sample handling robot for their upgraded life in laboratories.



### ● Specifications

Type		Specifications	Comment
Repeatability	GC Liquid Injection	< 0.60 % RSD	Alkanes C14,C15,C16, 1µL, split mode
	GC Headspace Injection	< 1.00 % RSD	Iso-octan, 5 µL in 20 mL vial, 500µL injection
Carry Over	GC Liquid Injection	< 0.004 %	Alkane Mix, 6.0 g/L in cyclohexane, 1 µL injected 2 mL vials filled to 50 %
	GC Headspace Injection	< 0.05 %	Iso-octan, 5 µL in 20 mL vial, 500µL injection
GC Liquid Injection, Linearity (Gravimetric)		R > 0.9999	20, 40, 60, 80, 100µL, n=3 each level
GC Needle Discrimination		C40/C20 > 0.98	Restek Florida Mix 1µL, 100ms fast split/splitless injection

### ● Sample Capacity

	Standard x-axis length (85 cm)	Extended x-axis length (120 cm)
Sample Capacity	4 Tray Holders Up to 840 1mL vials 648 2mL vials 180 10/20mL vials 12 MT/DW plates	6 Tray Holders Up to 1260 1mL vials 972 2mL vials 270 10/20mL vials 18 MT/DW plates
Sample Capacity Temperature Controlled (4-40°C)	Max. 3 Peltier Stacks Up to 1260 1mL vials (with 6DW) 972 2mL vials 270 10mL vials 18 MT/DW plates	Max. 4 Peltier Stacks Up to 1680 1mL vials (with 6DW) 1296 2mL vials 360 10mL vials 24 MT/DW plates 9216 samples (with 384 well MTPs)

# Innovative Features Giving Real Benefits

## Bottom Sensing

### Minimized Carryover and Reproducible Injection of Minute Sample Volume

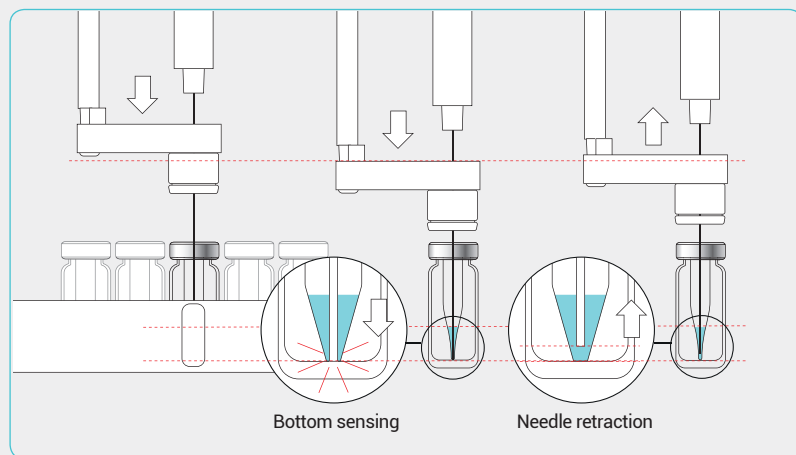

Bottom sensing makes sure that small volume can be injected out of a little  $\mu\text{L}$  of sample. (3 injections of  $1 \mu\text{L}$  out of  $5 \mu\text{L}$  sample)

With Constant Force Technology, the PAL detects the correct position of the needle in the specially designed needle seal. Potential carryover is avoided.

## Process Safety

Position detection means process safety with proprietary drive technology that enables the detection of missing vials and the correct position of the syringe needle in the injector port. Also, position detection for the temperature controlled stack ensures that the drawer is in the correct position (open / closed) and the temperature is monitored.

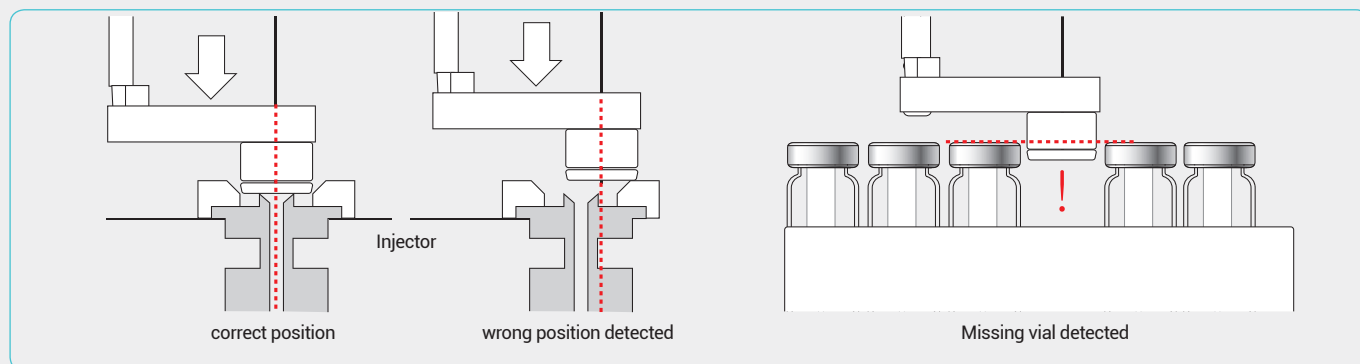

## Discrimination Free Injection

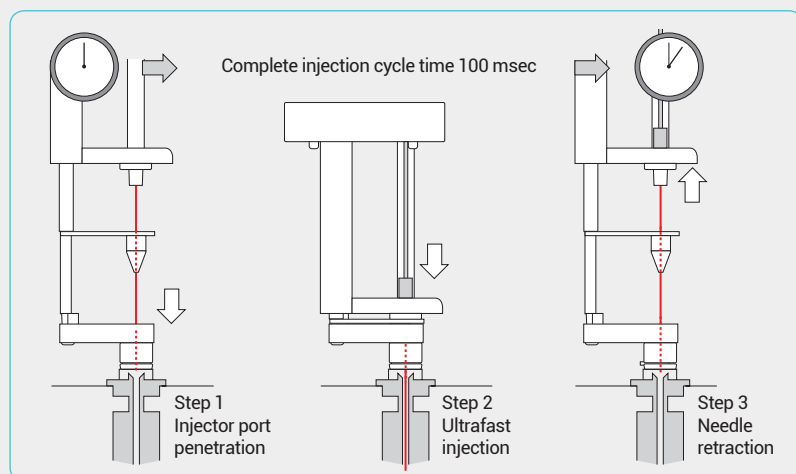

Ultrafast injection down to 100 msec reduces needle discrimination in GC to  $C_{40}/C_{20} > 0.98$ .

## Large Sample Capacity

162 x 2 mL-vials or 45 x 10 mL/20 mL-vials can be stored on one tray holder. It means the standard PAL LSI can hold 648 x 2 mL-vials and the standard PAL RSI/RTC can hold 180 x 10 mL/20 mL-vials on four tray holders. With the optional peltier stack, samples can be stored at a controlled temperature.

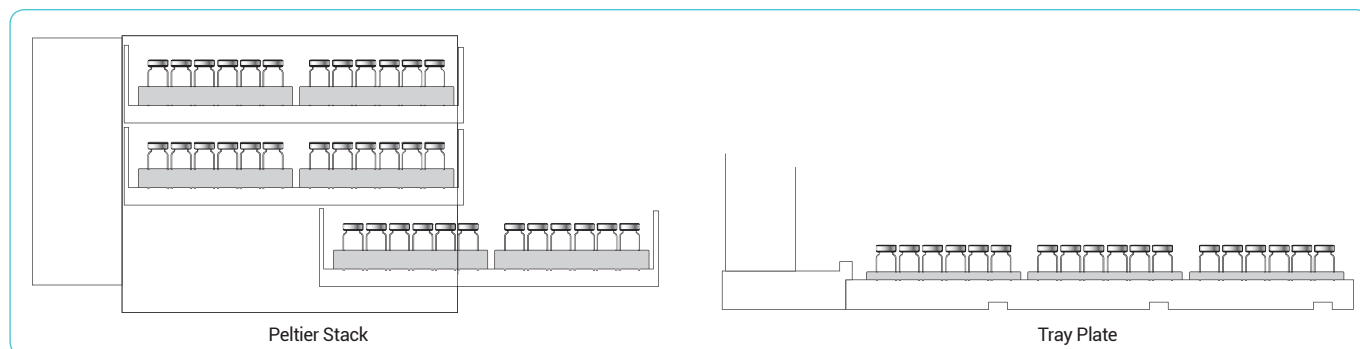

## Automatic Vial Transport



ChroZen PAL systems can reach any three dimensional position within its working area. It is able to transport vials to read barcodes or to transfer the vials into temperature controlled modules like the agitator for heating samples or the peltier stack for cooling them down to 4 °C.

## Robotic Tool Change(ChroZen PAL RTC only)

Fully automated sample preparation enabled by Robotic Tool Change(RTC)

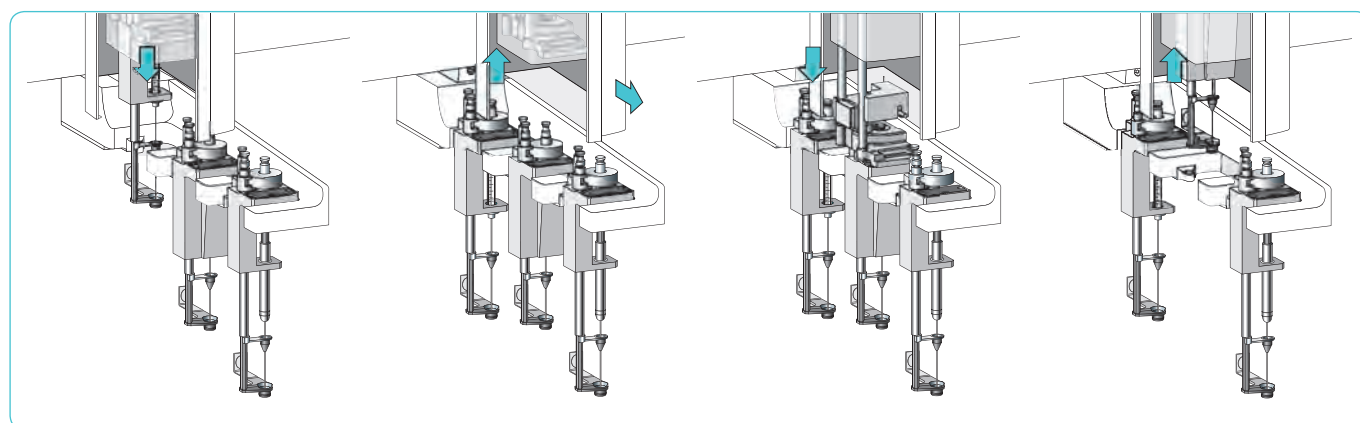

## Wide Range of Optional Modules for ChroZen PAL LSI and RSI/RTC systems

### Tray Plate

Additional tray plates increase the sample capacity. Supported vial formats are 1, 2, 10 and 20 mL, as well as 96 / 384 well microtiter plates and deep well plates. Up to 648 x 2 mL vials, 180 x 10/20 mL vials or 12 MTPs can be stored.



### Peltier Stack Module

Temperature controlled peltier stacks for 2 or 6 sample trays or plates can be added to cool samples preventing degradation or to heat samples for derivatization reactions or kinetic studies.



### Wash Module

The standard wash module is ideal for washing the syringe with up to four different solvents (4 x 10 mL solvent vial, 1 x 10 mL waste vial). An optional waste tube is available.

The large wash module is ideal for large volume injections (2 x 100 mL glass solvent container, waste port with tubing olive).



### Fast Wash Module

The fast wash module is preferred when low carry-over is required. It also cleans syringes including the outside of the needle (gauge 19 ~ 26) with 2 different solvents.



### Vortex Mixer

The vortex mixer module offers efficient mixing for dilution / extraction.

- Standard vial sizes: 2 mL / 10 mL / 20 mL
- 1 additional slot for customized specific vials
- Providing efficient mixing with up to 2000 rpm



### Barcode Reader Module

The barcode reader module reads horizontal 1D barcode labels on 2 mL, 10 mL and 20 mL vials. The two active laser scanners allow the identification of vials irrespective of the position of the barcode on the vials. Therefore, it ensures the highest process safety and traceability.



# Wide Range of Optional Tools and Modules for ChroZen PAL RSI/RTC systems

## Park Station(RTC only)

The unique park station allows a robotic tool change for advanced sample preparation, derivatization steps or any other time consuming repetitive step. The additional versatility in combination with the increased volume range are significant benefits and allow the realization of flexible tailor-made automation processes.

- 1 park station for up to three injection tools
- Installation of up to 2 park stations on one PAL RTC
- Designed for automated screening of method conditions with multiple tools



## Liquid Syringe Tool

- Supporting 57mm or 85mm syringe needle length
- Available syringes: 1.2  $\mu$ L / 5  $\mu$ L / 10  $\mu$ L / 100  $\mu$ L with D7 tool

## Static Headspace Tool

- Three different syringes available: 1 mL / 2.5 mL / 5 mL
- Syringe temperature 40°C up to 150°C in 1°C step
- Syringe flush with inert gas flow through X-Y-Z rail

## ITEX Dynamic Headspace

- Alternative solution of Purge & Trap
- Rapid and efficient enrichment of samples in trace level
- In-tube extraction and thermal desorption using industry standard adsorbents
- Syringe-only concept: no sample loops, transfer lines, or switching valves that could be contaminated
- Active cooling of the tool allows fast sample preparation

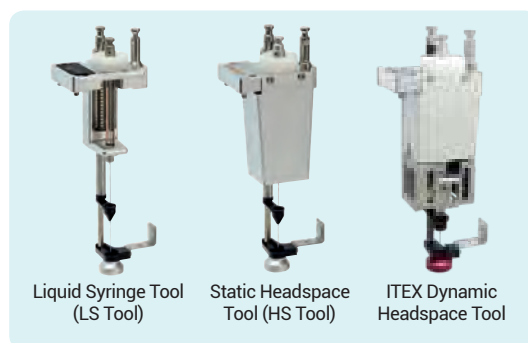

## SPME Fiber Tool

- New SPME holder for increased fiber protection
- Compatible with a variety of SPME fibers
- Easy fiber exchange by hand for 10 mm or 20 mm fiber length

## SPME Arrow Tool

- Trace level sensitivity
- High mechanical robustness
- Large sorption phase surfaces and volumes
- Faster extraction & higher sensitivity than SPME fiber

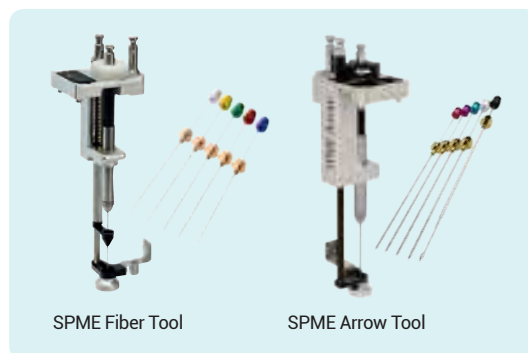

## Agitator Module

The agitator module provides 6 positions for 20 mL vials for incubation and agitation of samples.

- Temperature range 40 ~ 200°C
- Agitation speed 250 ~ 750 rpm
- Optional adapters for 2 mL or 10 mL vials



## SPME Arrow Conditioning Module(for SPME Fiber/Arrow Tool)

- Temperature range up to 350°C
- Integrated automated purge gas valve
- Manual gas valve for pre-conditioning
- Replacement liners for easy maintenance





Our products are endorsed by Korean PPS  
(Public Procurement Service) in recognition of their  
excellent technologies and the product quality.



## ChroZen PAL System



### YOUNG IN Chromass

The iDEA makes iDEAL!  KOREA MADE

Address : 60, Anyangcheondong-ro, Dongan-gu, Anyang-si, Gyeonggi-do, 14042, Korea  
TEL: +82-31-428-8700 / FAX: +82-31-428-8787  
E-mail: [export@youngincm.com](mailto:export@youngincm.com)  
Homepage: [www.youngincm.com](http://www.youngincm.com)