



CE

CDS 6000 Series Pyroprobe

- **Thermal GC Injection** Systems for Pyrolysis, Thermal Desorption, Dynamic Headspace, and Evolved Gas

Introduction

CDS Analytical is celebrating its 50th anniversary. CDS Analytical was founded by Dr. Eugene Levy in Nottingham, PA in 1969, and moved to its state-of-the-art Oxford, PA facility in 1981. Over the past 50 years, CDS Analytical has been expanding its core business from Analytical Pyrolysis to a full range of GC Sample Introduction methods, including Thermal Desorption, Purge & Trap, and Dynamic Headspace.

As of today, CDS Analytical gathers world-class engineers and analytical chemists working together to continue the "Made in USA" legend. We provide the best tool to our customers in Analytical Chemistry by packaging our continuous innovations in hardware, software, technology and applications into a complete solution.

The 6000 Series Pyroprobe is the 6th generation pyrolyzer proudly designed and manufactured by CDS Analytical. It is a revolutionary product with many unparalleled features to add value to your GC/MS system.

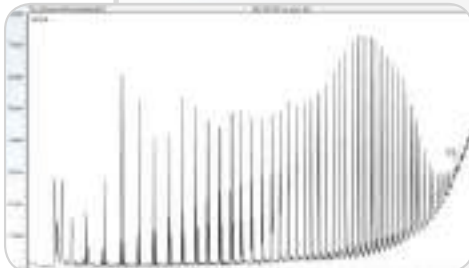
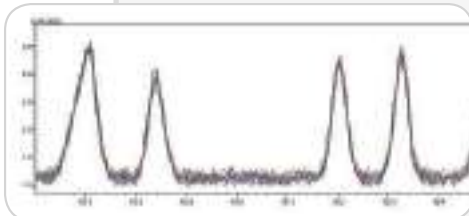

Easy Sample Loading

The 6000 Series Pyroprobe is equipped with a novel Drop-In-Sample Chamber (DISC) as a standard configuration. When coupled with the DISC sample tube, the sample preparation process no longer requires quartz wool and the sample loading is as easy as dropping a straw into a drink.

Unparalleled Reproducibility

Reproducibility with a thermal technique depends greatly on temperature accuracy. The DISC solution brings several important improvements over previous generations: (1) temperature accuracy at ± 0.1 °C, (2) calibrated sample temperature calibrated through optical pyrometry, (3) guaranteed sample placement. This translates to 1.5% RSD for 5 run pyrolysis Polystyrene at 500°C.

Hybrid-Driven Autosampler

The redesigned conveyor-fed autosampler module focuses on one thing - reliability. The novel hybrid driven system adopts gravity, the most reliable force in the world, to dispense and eject the DISC sample tube.

Superior Resolution

The 6000 Series Pyroprobe adopts computer-aided design, especially the Finite Element Analysis in the sample pathway development. The result is maximized instrument resolution. As a comparison, for pyrolyzing Polyethylene at 600 °C through GC with a single quad mass-spec as the detector, the 6000 Series Pyroprobe could reach C55 where our competition would stop typically at C43.

State-of-the-Art in Thermal Injection Systems

CDS pyrolyzers use a reliable and repeatable Platinum filament heating system. The proprietary energy storage system unleashes the high density electric energy to the low thermal mass filament with an amazing 20,000°C/second coil ramp up rate. This makes the sample reach the pyrolysis temperature nearly order-of-magnitude times faster than the furnace heating pyrolyzer. In each system, the sample temperature is calibrated with optical pyrometry with temperature accuracy at $\pm 0.1^\circ\text{C}$. The electronic system is capable of performing self-diagnosis, including the crucial leak-check function.



Coil and Ribbon Manual Insertion Probe Module



1/4" x 3.5" Thermal Desorption Tube Module



25 mL Test Tube Desorber Module



Tandem Reactor Module

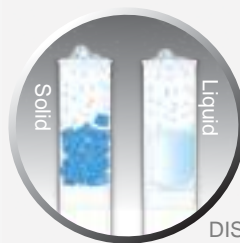

DISC Tube

Drop in Your Sample Here



- 1 DISC Tube for both Solid and Liquid Sample (No quartz wool required)
- 2 Precision Bore Platinum Coil Calibrated with Sample Temperature Accuracy at $\pm 0.1^\circ\text{C}$
- 3 Programmable Cooling Fan for VVOC Studies
- 4 Multi-Function Accessory Rack for Various Modules
- 5 Hybrid-Driven Mechanism to Dispense and Eject Sample

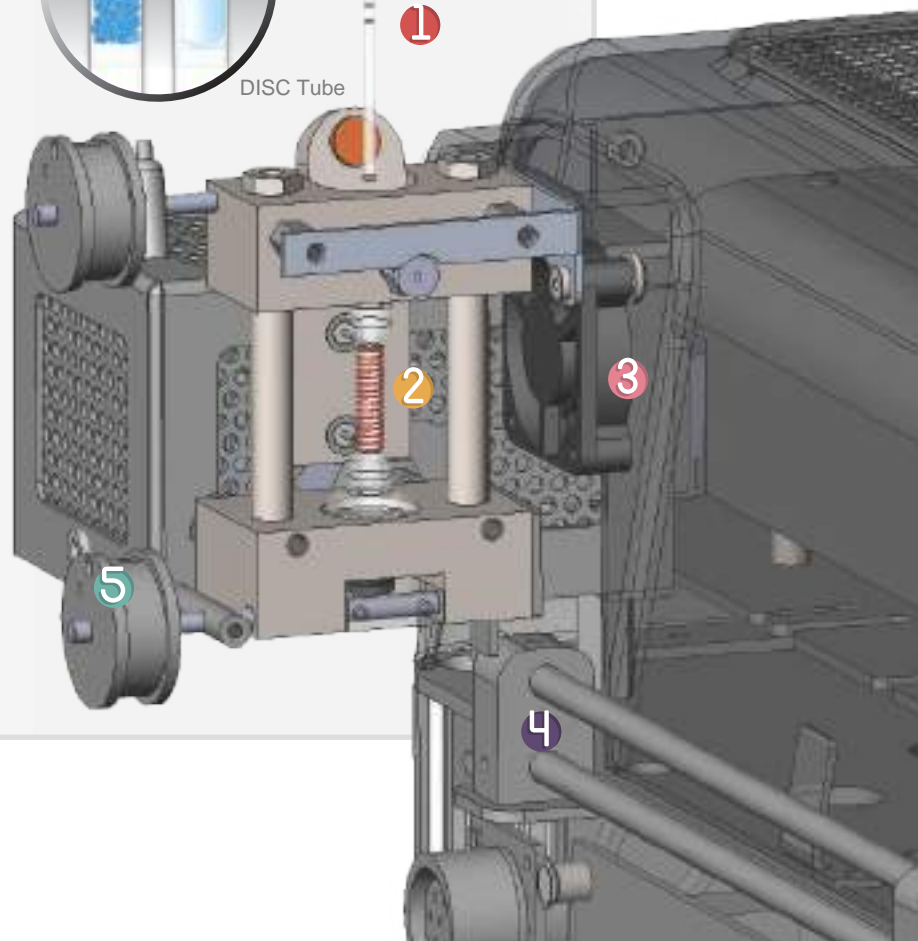

The CDS 6150 Pyroprobe

Our base model instrument for pyrolyzing in PY-GC mode only. The 6150 connects to any model GC by means of a heated transfer line for easy on/off installation.



Windows 10 Compatible Digital Control Interface (DCI)

Typical Applications:

- Evolved Gas Analysis (EGA) of Polymer with Additives
- Thermal Desorption of Phthalates
- Programmable Pyrolysis of Polymer with Additives



User-friendly Touch Screen Interface

Technical Comparison:

	CDS 6150	Frontier 3030S
Max Temperature	1300 °C	850 °C
Programmable Temperature	Yes, Up to 10 Steps	No
Max Temperature Ramp Rate	20,000 °C/s	Not Supported
Temperature Accuracy	±0.1 °C	±0.1 °C
RSD% (Polystyrene)	1.5%	2.0%
Leak Check	Yes	No
GC Mount	Transfer Line	Direct GC Mount
Sample Tube	Quartz	Various

The CDS Pyroprobe 6200

Compared to the 6150, the 6200 Pyroprobe has a built-in focus trap which enables the instrument to collect analytes using reactant gas (like oxygen and air), or perform thermal desorption on standard 1/4"x3.5" sorbent tubes, or dynamic headspace on large volume sample with optional modules to enhance the sensitivity.

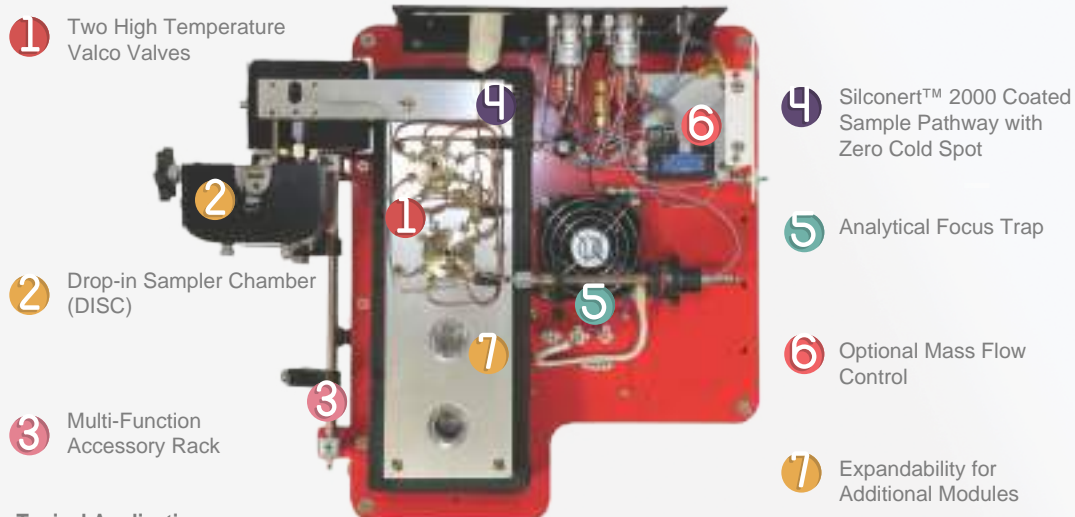

Typical Applications:

- Programmable Pyrolysis of Polymer with Additives
- Evolved Gas Analysis (EGA) of Polymer with Additives
- Thermal Desorption of Phthalates
- Reactive Pyrolysis in Air/O₂
- Tandem Pyrolysis through External Reactor
- Thermal Desorption for EPA TO-17
- Dynamic Headspace for VOC and SVOC

Technical Comparison:

	CDS 6200	Frontier 3030D
Max Temperature	1300°C	1050 °C
Programmable Temperature	10 Steps	4 Steps
Max Temperature Ramp Rate	20,000 °C/s	1 °C/s
Temperature Accuracy	±0.1°C	±0.1°C
RSD% (Polystyrene)	1.5%	2.0%
GC Mount	Transfer Line	Direct GC Mount
Leak Check	Yes	No
Focus Trap	Standard	Optional
CryoTrap	Optional (-198°C)	Optional (-196°C)
Cooling Gas	Not Required	Required
Reactant Gas	Standard	Optional
Thermal Desorption Tube Adapter	Available	Not Available
Dynamic Headspace Adapter	Available	Not Available

The CDS 6000 Series Autosampler Module

The 6000 Series Autosampler module provides extremely reliable automated pyrolysis. Solids, viscous liquids, and powder samples are pyrolyzed in the Drop-In-Sample-Chamber (DISC) with a reliable automated sample loading mechanism (48 slots) fulfilled by this module. The autosampler module further opens up the programmable temperature capability from 10 temperature-step per sample to infinite temperature-step per sample. This autosampler module is compatible with both 6150 and 6200 Pyroprobe and adopts Dynamic Sequence Table function to allow user to add in emergency samples without interrupting scheduled samples.



1



Heavy Duty 48 Position Conveyor

2



High Precision Step Motor

3



Hybrid Driven Mechanism

4



Dynamic Sequence Table

Technical Comparison:

	CDS 6000 Autosampler	Frontier 3030D/AS-1020E
Sample Positions	48	48
Programmable Temperature	Infinite Steps	8 Steps
Max Temperature	1300 °C	1050 °C
Temperature Accuracy	±0.1°C	±0.1°C
RSD% (Polystyrene)	1.5%	2.0%
Leak Check	Yes	No
Dynamic Sequence Table	Yes	No
Mount	On the Side of Pyrolyzer	On GC
Sample Loading/Unloading	Gravity	Gravity In and Gas Out

Polymer Library

Since the analytical process of pyrolysis is to break down a polymer to volatile fragments, the MS can only identify the fragments, and not the original polymer. To help address this need, CDS has developed an effective means of searching unknown pyrograms with your existing MS to identify the polymer used in the sample matrix.

The CDS polymer library is built on 500+ individually averaged spectra of industry standard polymers. When you run a sample through your GC/MS, you simply average the complete TIC spectra and then compare it to the CDS Polymer Library. Similar to results obtained from a NIST search, you will have a list of possible matches from the CDS library.

Combining averaged mass spectra with a pyrogram TIC creates a powerful two-prong method of polymeric material analysis. The technique allows analysis of individual pyrogram peaks using standard searching libraries while offering the polymer's chromatographic pattern characteristics. It also allows users to apply existing computer searching techniques to the polymer as a whole.

And, you have the ability to add your own standards to the library. This is accomplished by running your standard, averaging the TIC spectra and then entering it as a file into the CDS library. As we continue to build upon our own library, you will have access to free library upgrades for the life of your instrument, so you will be assured that you have the latest data interpretation tools commercially available.

Current compounds in the library include most of the common industrial polymers in use today, copolymers, finished products and even biopolymers. See figure xxx (include example of polymer search).



Polymer Additive Identification

The number of polymer additives today is vast and growing constantly, making it increasingly difficult to detect trace-level additives in a polymer sample. To tackle this analytical challenge, CDS has assembled an additive library containing 500+ compounds, many of which are not found in a NIST or Wiley library. Our library is used with one of several leading deconvolution software packages, such as AMDIS (available free from NIST), Chemstation or Masshunter.

By pairing deconvolution software with the CDS Additive Library, users can search chromatograms (from pyrolyzed or thermally desorbed samples) by specific compound or compound categories. Our library is compatible with most major MS softwares, providing they use a compatible deconvolution package noted above. The software searches and identifies additives stored in the library and can be used down to the ppm level.

Supplement the knowledge base yourself, and take advantage of the regular stream of CDS updates as you wish. Since additives are grouped by category you can limit searches to ones of interest only.





Thermal Desorption

Pyrolysis

Purge and Trap

CDS Analytical Headquarters:

465 Limestone Road P.O. Box 277 Oxford, PA 19363-0277 Tel: 800.541.6593 610.932.3636 www.cdsanalytical.com